

ANTENNA/TUBE ADAPTER HEAVY DUTY

THE ANTENNA / TUBE HEAVY DUTY ADAPTERS

are designed for installation of one panel antenna on vertical structures creating an offset distance of 275-295 mm (10,8-11,6 in) to the vertical structure (depending on the shape of the structure). The heavy duty adapters can handle high wind speeds.

FLEXIBILITY

The Antenna Adapter fits all common Kathrein and Huawei panel antennas. The Tube Adapter fits a Ø60 tube.

The Adapters can handle a wide range of all common frame leg designs, round, square, angular etc.

QUALITY

The sheet metal parts are made of Magnelis steel, the clamps are made of anodized aluminum and all fasteners are made of acid proof stainless steel. This gives the mount excellent corrosion resistance.

EASY ASSEMBLY

Handling and installation is very easy thanks to its light weight but also thanks to its clever design with elongated opening holes allowing the clamps to be opened and closed without any loose parts which rapidly speeds up the installation. The adapter is pre-assembled at delivery which further simplifies the installation.

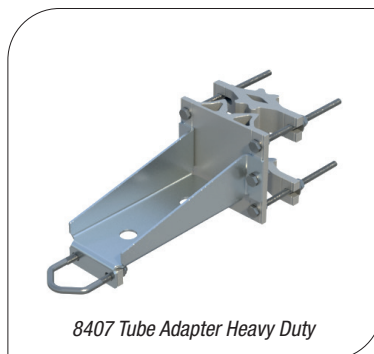
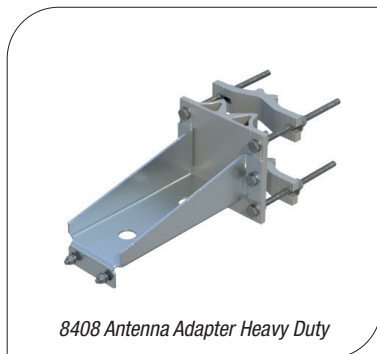
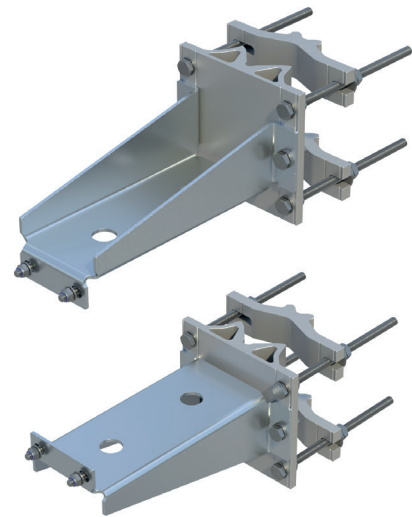

ORDER AND TECHNICAL INFORMATION

DRAWING NO: CD 991307 / CD 991306

FUNCTION DESCRIPTION: Antenna Adapter Heavy Duty for installation of one antenna / Ø60 tube with an offset distance of 275-295 mm (10,8-11,6 in) to the vertical structure at high wind speeds.

MOUNTING SPAN:	TUBES:	SQUARE PROFILES:	90° ANGLE:	60° ANGLE:
	○	□	∨	∨
Minimum	Ø25 mm (1,0 in)	35 x 35 mm (1,4 x 1,4 in)	35 x 35 mm (1,4 x 1,4 in)	40 mm (1,6 in) opening
Maximum	Ø120 mm (4,7 in)	90 x 90 mm (3,5 x 3,5 in)	90 x 90 mm (3,5 x 3,5 in)	100 mm (4,0 in) opening
Mounting tubes	Ø60mm (2,4 in) (applies to Tube Adapter)			

PACKAGE DIMENSIONS:	LENGTH:	WIDTH:	HEIGHT:	WEIGHT:
	575 mm (22,6 in)	180 mm (7,1 in)	190 mm (7,5 in)	9,2/9,7 kg (20/21 lb)

NOTE! Mounting tubes are not included. Must be ordered separately.

Quality Design